

Type 55-01-11 Weigh Module

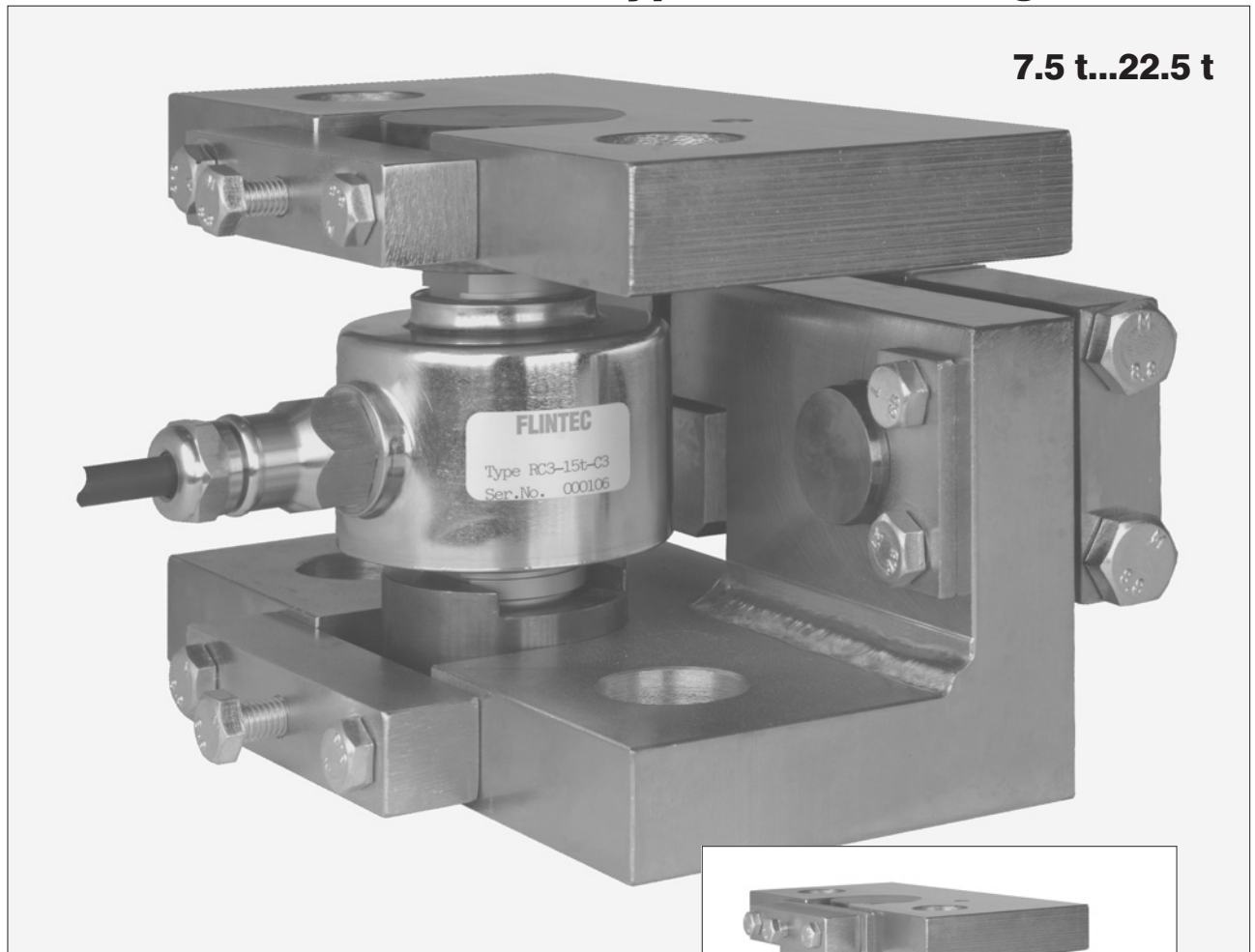

Weigh Module 55-01-11 with RC3 Load Cell

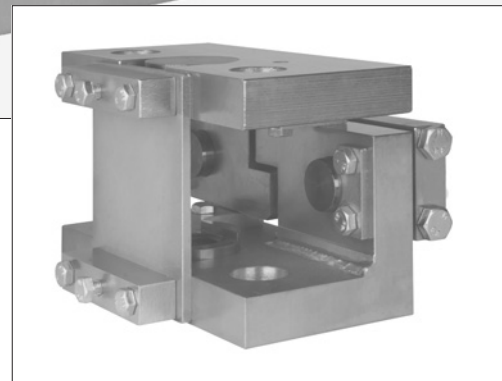

Pre-assembled module

Flintec load cell supports are designed to prevent unwanted forces from affecting load cell performance. The Type 55-01-11 is a self aligning weigh module, with excellent load introduction.

The module is especially designed for using Flintec rocker column load cells in hopper and tank weighing applications and incorporates an integrated check link to eliminate oscillations caused by slow moving agitators etc.

The Weigh Module will be shipped completely pre-assembled including a blocking plate; ready for installation by welding or bolting.

Material: steel, zinc plated; alternatively stainless steel.

Important Features

- Capacities 7.5 t, 15 t and 22.5 t.
- Very easy to install.
- Very rugged.
- Especially designed for hopper and tank weighing with slow moving agitators.
- With integrated lift off protection.
- Load cell replacement requires minimum lifting height.

Dimensions

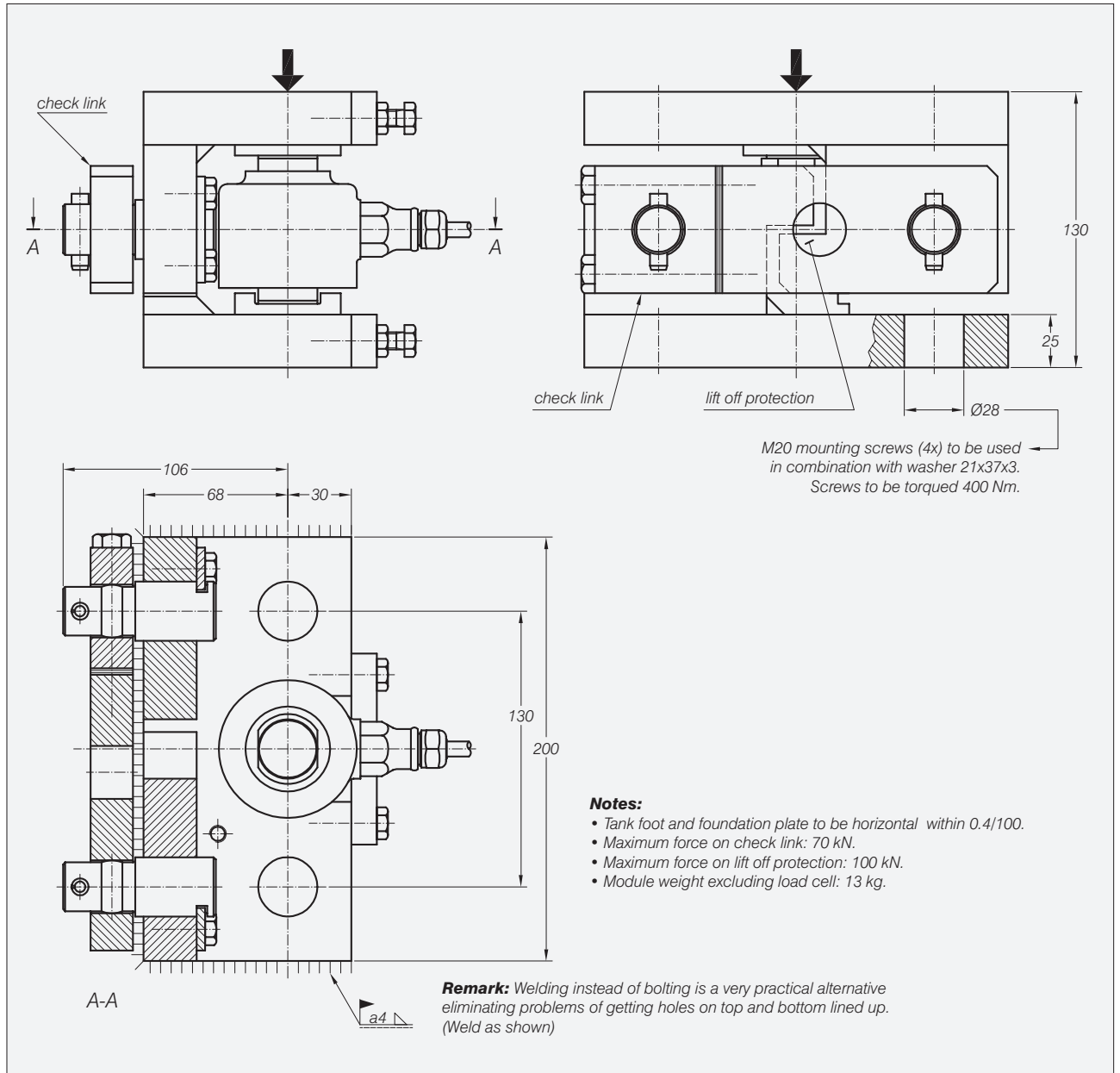

All dimensions in mm. Dimensions and specifications are subject to change without notice. Assembly drawings with installation instructions and CAD files for customer's own applications drawings are available on request.

Note:

3 Loading points are equipped with check links; all others without check link. See page: Check link orientation.

Module assembled for shipment and installation

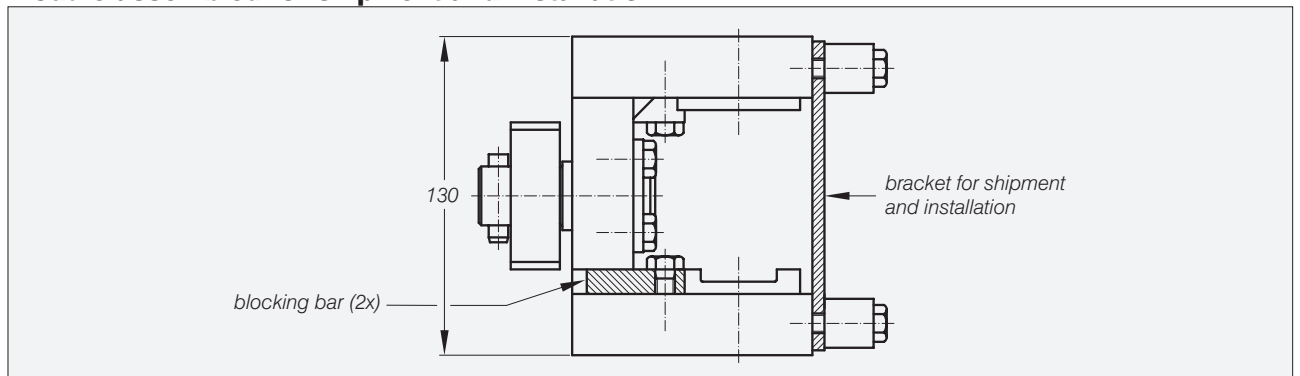

Check link orientation

4 LOAD CELLS

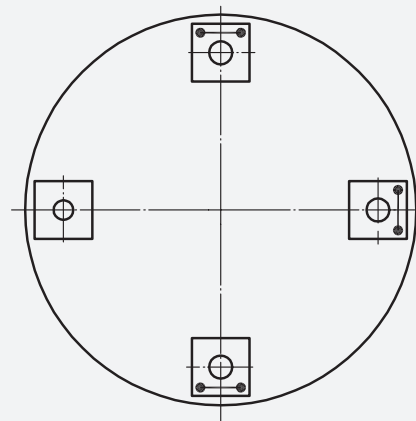
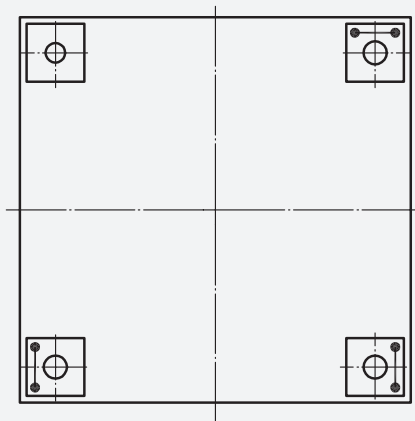

3 LOAD CELLS

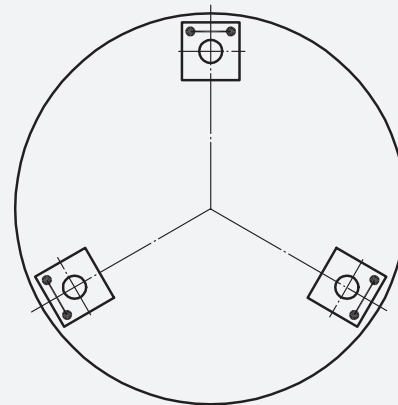
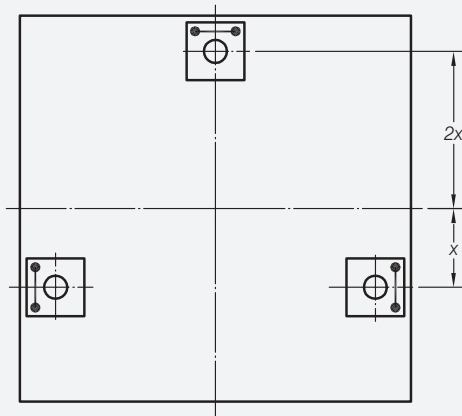

drawing symbols



unit with check link



unit without check link